

Garduri din tablă decupată

Instrucțiuni de montaj

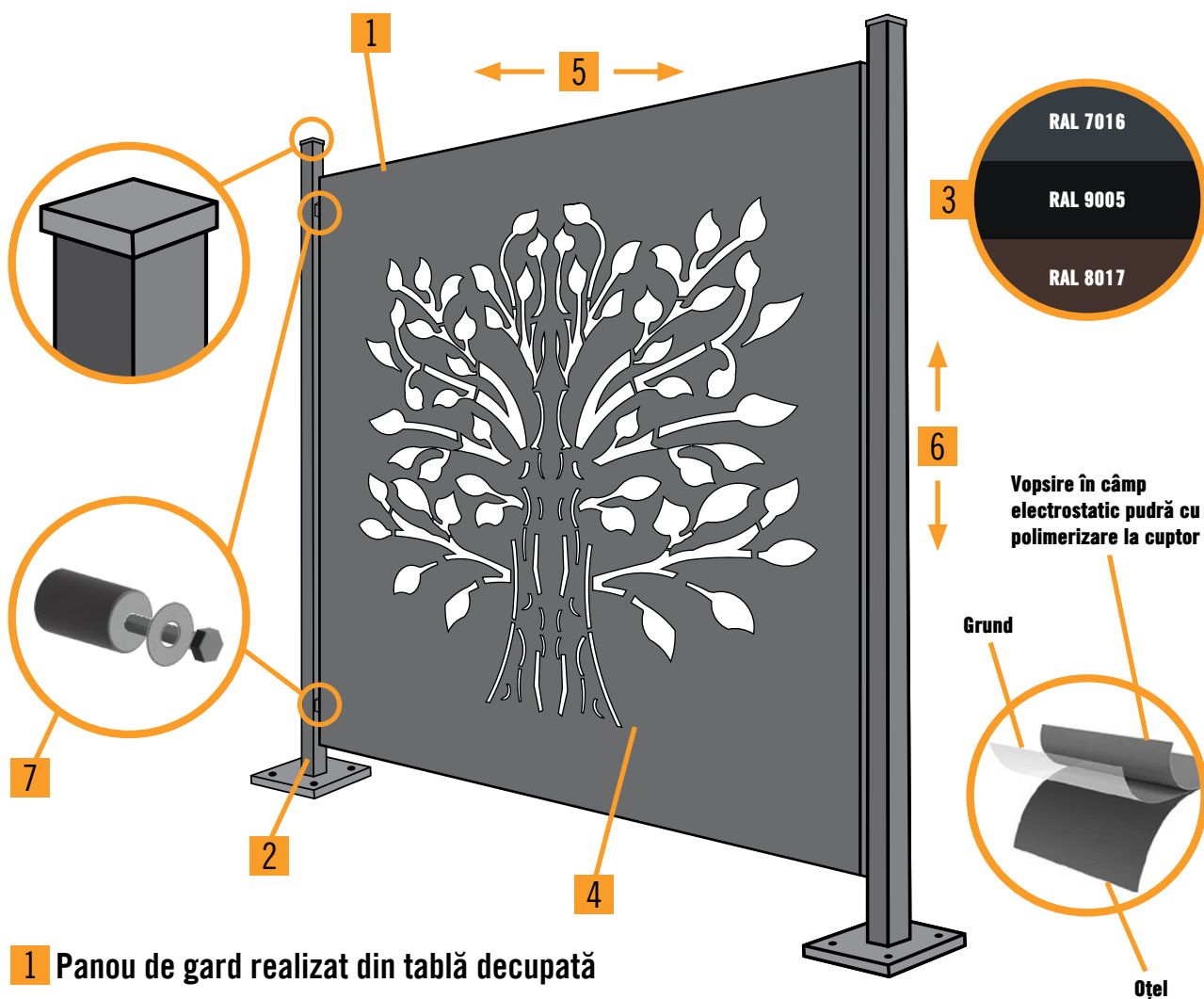

Pasul 1

Montarea stâlpilor

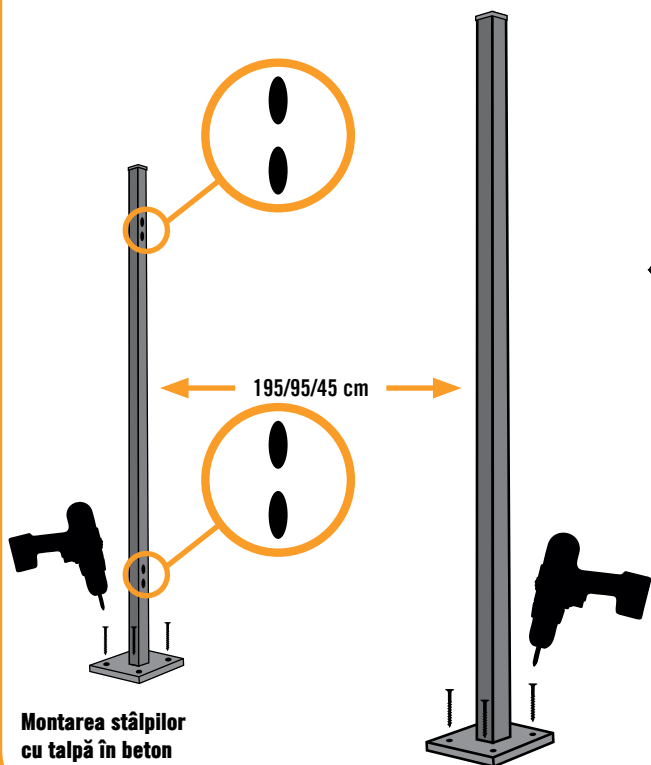

Pasul 2

Plasarea panoului în poziția de montaj

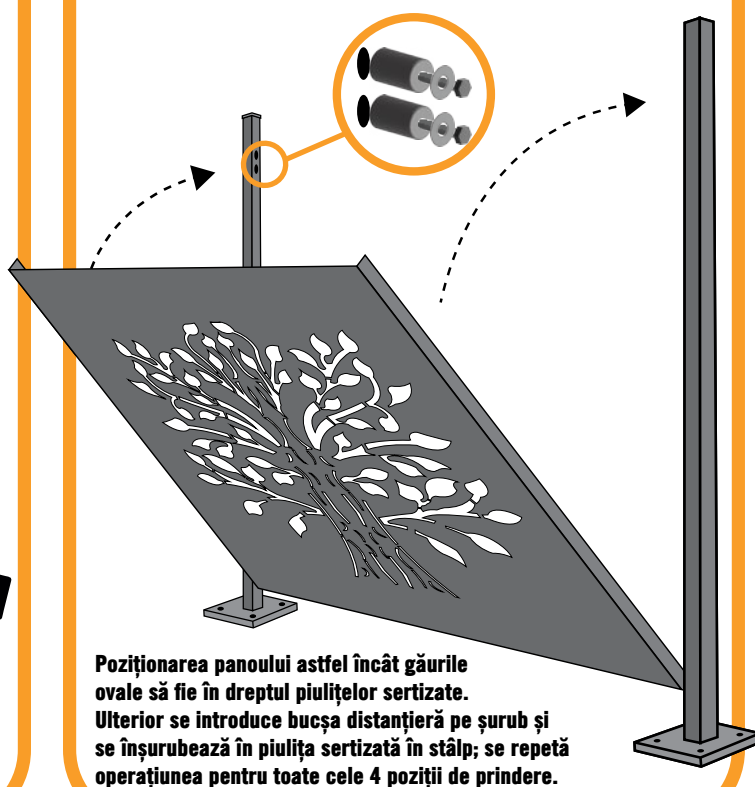

Pasul 3

Dupa alinierea tuturor panourilor și reglarea acestora, se strâng șuruburile

